



## IBUG Fall User Group Meeting September 28<sup>th</sup> 2011

Precision Input with AccuDraw

Steven Rick – Bentley Systems, Inc.

# IBUG Fall User Group Meeting September 28<sup>th</sup> 2011



## Trademarks

AccuDraw, Bentley, the “B” Bentley logo, MDL, MicroStation and SmartLine are registered trademarks; PopSet and Raster Manager are trademarks; Bentley SELECT is a service mark of Bentley Systems, Incorporated or Bentley Software, Inc.

Java and all Java-based trademarks and logos are trademarks or registered trademarks of Sun Microsystems, Inc. in the U.S. and other countries.

Adobe, the Adobe logo, Acrobat, the Acrobat logo, Distiller, Exchange, and PostScript are trademarks of Adobe Systems Incorporated.

Windows, Microsoft and Visual Basic are registered trademarks of Microsoft Corporation.

AutoCAD is a registered trademark of Autodesk, Inc.

Other brands and product names are the trademarks of their respective owners.

## Patents

United States Patent Nos. 5,815,415 and 5,784,068 and 6,199,125.

## Copyrights

©2000-2009 Bentley Systems, Incorporated.

MicroStation ©1998 Bentley Systems, Incorporated.

IGDS file formats ©1981-1988 Intergraph Corporation.

Intergraph Raster File Formats ©1993 Intergraph Corporation.

Portions ©1992 – 1994 Summit Software Company.

Portions ©1992 – 1997 Spotlight Graphics, Inc.

Portions ©1993 – 1995 Criterion Software Ltd. and its licensors.

Portions ©1992 – 1998 Sun Microsystems, Inc.

Portions ©Unigraphics Solutions, Inc.

Icc ©1991 – 1995 by AT&T, Christopher W. Fraser, and David R. Hanson. All rights reserved.

Portions ©1997 – 1999 HMR, Inc. All rights reserved.

Portions ©1992 – 1997 STEP Tools, Inc.

Sentry Spelling-Checker Engine ©1993 Wintertree Software Inc.

Unpublished – rights reserved under the copyright laws of the United States and other countries. All rights reserved.

# IBUG Fall User Group Meeting September 28<sup>th</sup> 2011



## The AccuDraw workflow

If you plan to use AccuDraw you may need to change your workflow because, when enabled, AccuDraw considers three things and changes its behavior accordingly.

First, it considers at the current tool. For example, if the active tool is Place Block it will remain in a Rectangular mode which is expressed as X and Y distances from its origin. If the selected tool is Place Arc, AccuDraw will automatically switch to Polar mode which is expressed as distance and angle.

Second, AccuDraw considers the location of the pointer with respect to its origin. As you move the pointer around the compass, AccuDraw automatically updates the X and Y values in the AccuDraw window's key-in fields to reflect the distance the pointer is from its origin. If no data point is entered, the values show absolute coordinates.

Finally, AccuDraw considers and interprets keyboard shortcuts. These are single or dual character key-ins to drive its behavior. An example is using the space bar to toggle between the Rectangular and Polar modes.

The mouse is one of the ways that AccuDraw infers information. When mouse moves, AccuDraw tracks the pointer's location in relationship to the AccuDraw compass. The operational rules of AccuDraw are as follows.

1. Enter a data point either using precision input, or a data point, to fix the location of the compass.
2. Move the pointer in the direction in which you wish to draw.
3. Without using the pointer to put focus into the AccuDraw window' key-in fields, enter the desired distance value.
4. <Optional> move in another direction.
5. <Optional> enter another distance value.
6. Enter a data point to accept.
7. Repeat from step 2 to continue drawing.

The important thing to remember is that you move in the direction you wish to draw. You do not need to consider whether you are moving in the X dimension or Y dimension.

You know the direction in which you need to draw by looking at your notes and plans. Focus on the direction, not the X or Y dimension. The X and Y dimensions are useful, but when drawing they are not be the focus.



### The input focus

As you move the pointer around the screen, AccuDraw continually updates the field that is currently active in the AccuDraw window. It is indicated by the highlighted field title. AccuDraw's input focus lets you enter values wherever the insertion bar is highlighted.

If the pointer's movement away from the previous data point includes a higher X value than the Y value, the input focus appears in the X field. If the pointer's movement away from the previous data point includes a higher Y value than the X value, then the input focus appears in the Y field.

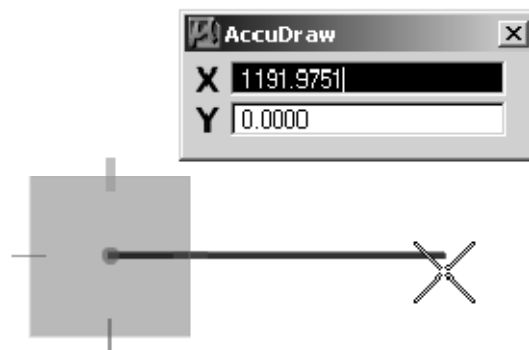

*Move in the X direction and focus is in the X- field*

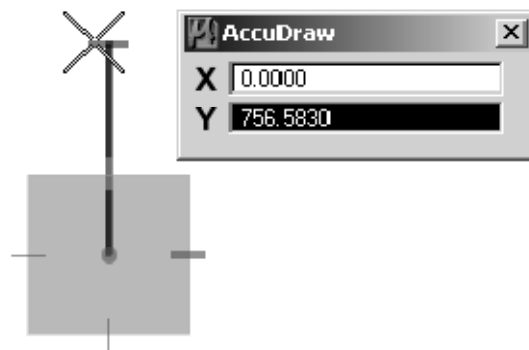

*Move in Y direction and focus is in the Y- field*

### AccuDraw indexing

AccuDraw can index to axes, the origin and the previous distance. The indexing feature works like AccuSnap. If you get close to an indexing state, the pointer temporarily locks onto to that state.

For example, when the pointer nears a 90 degree angle to the origin of the compass it will index to that angle. In this way it can replace the axis (Ortho) lock in all but a few situations.



## Drawing with AccuDraw

The next task is to draw the following object using AccuDraw and SmartLines.

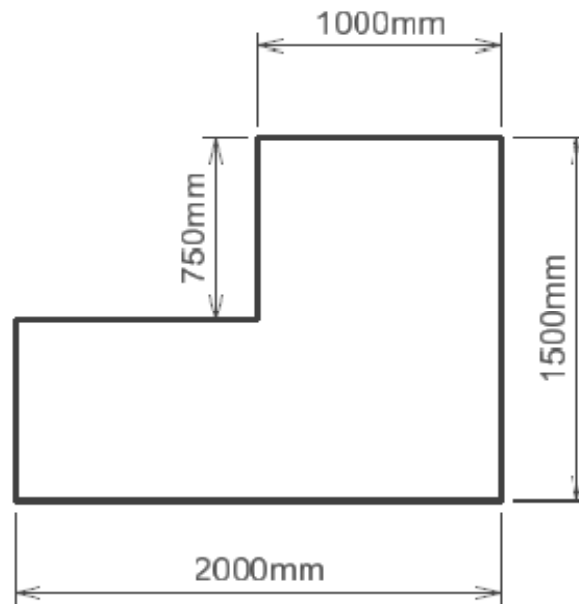

*You can calculate the missing dimensions from the information given*

You will start at the lower left and move in a counter-clockwise direction.

➤ **Exercise: Basic drawing with AccuDraw**

1. Continuing in Base Geometry.dgn, Pan to an open area of the design.
2. Select Place SmartLine (Q + 1).
3. Note the status bar prompt and enter a data point anywhere to start. This is the first vertex of the element and the AccuDraw compass appears at the data point location.
4. Move the pointer to the right, lining up with the X-axis. This is called indexing.

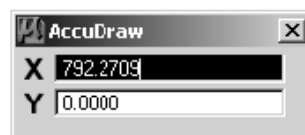
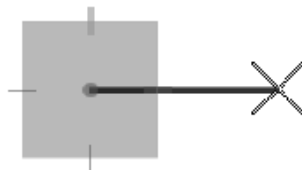



5. Without moving the pointer into the AccuDraw window, enter 2000.
6. Enter a data point to accept the value.

Note that the compass moves to the last data point.

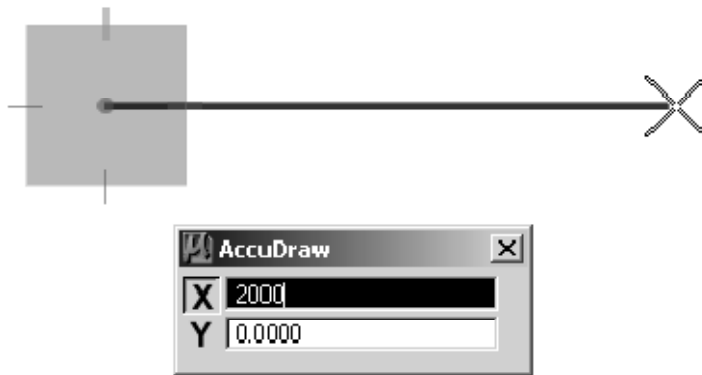

7. Move the pointer upward and line up with, or index to, the Y-axis.

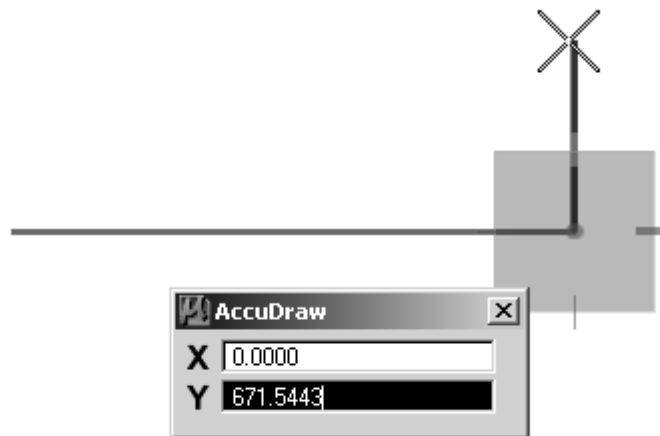

8. Enter 1500 and accept with a data point.

# IBUG Fall User Group Meeting September 28<sup>th</sup> 2011



9. Move the pointer to the left and index to the X-axis.
10. Enter 1000 and accept with a data point.

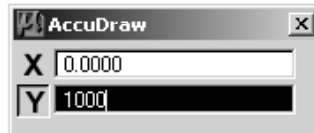
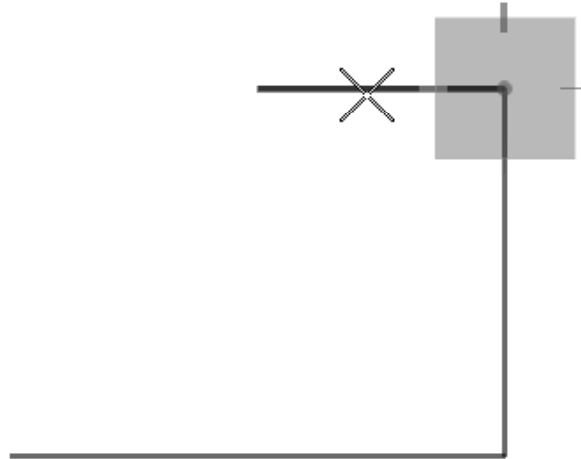

11. Move the pointer downward and index to the Y-axis.
12. Enter 750 and enter a data point to accept.

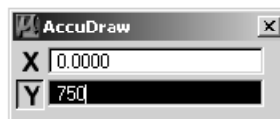
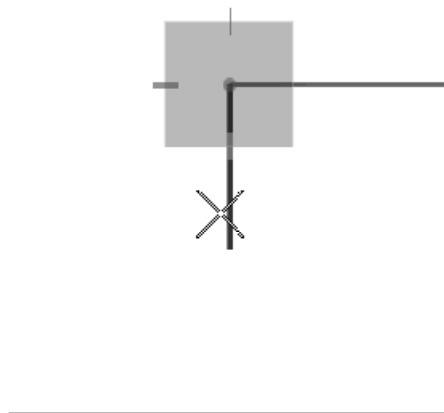



13. Move the pointer to the left, index to the X-axis, enter 1000, and accept with a data point.

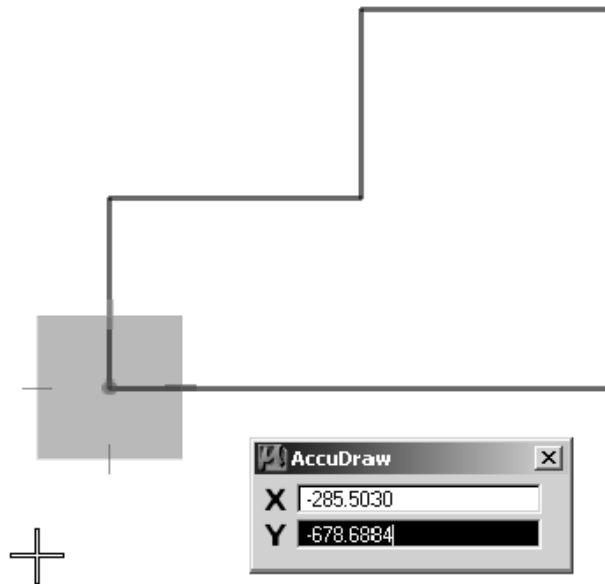

14. Move the pointer downward, index to the Y-axis and enter 750 to close the shape.

✓ **TIP:** Keep the mouse steady. If you move the mouse around too much, indexing will be lost.

### Locking coordinate values

When you enter a value from the keyboard AccuDraw locks the current input field and immediately affects the pointer's motion because it knows you are entering coordinate data.

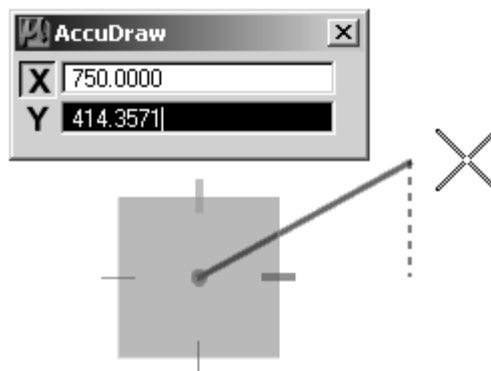

After entering a value in the first field, move the pointer until the input focus changes to the other field and you can enter the other value. The coordinates you have entered establish a point for the placement of the element.

# IBUG Fall User Group Meeting September 28<sup>th</sup> 2011



## AccuDraw Shortcuts

AccuDraw's behavior is influenced by the current tool, the location of the pointer and keyboard shortcuts. AccuDraw anticipates your next move. Sometimes, however, you will want to direct AccuDraw, so there are a variety of single and double character command directives known as the shortcut key-ins. By pressing the appropriate key while focus is in the AccuDraw window you can direct AccuDraw to perform a specific task.

These shortcuts only work when the AccuDraw window has the focus (is the active window). When you select a tool, the focus does not go to the AccuDraw window. When you enter a data point to start using the tool, then the focus will shift to the AccuDraw window.

- **NOTE:** Press ESC then the space bar to move the focus to the AccuDraw window.

To open a window showing a list of all AccuDraw shortcuts, **press the ? key**. This is the only shortcut you need to memorize, since it will show you all the rest.

### Exercise: Focus and the ? shortcut

1. Continuing in Base Geometry.dgn, select Place SmartLine (Q + 1).

Note that focus remains at home.

2. Press F11 to shift the focus to AccuDraw.
3. Press the <?> key and expand the AccuDraw Shortcuts window.

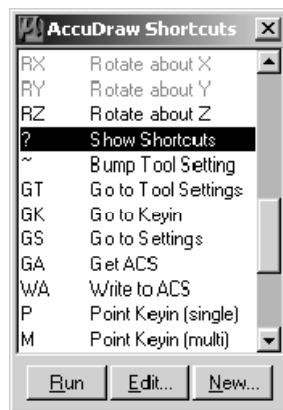

4. Return focus to the AccuDraw window by pressing F11.



- 5. Press G then T, <GT>, to move focus to the tool settings window

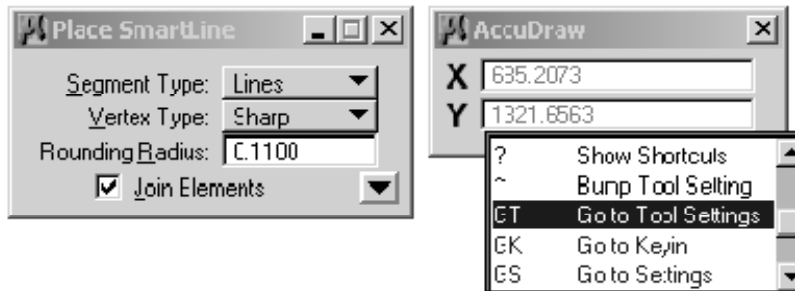

- **NOTE:** The focus can also be moved to the tool settings window by pressing F10.

### Important basic shortcuts

#### Space Bar = Change display mode

The space bar toggles between Rectangular and Polar mode.



#### X = toggle X lock, Y = toggle Y lock

The <X> or <Y> keys can be selected at any time to lock or unlock the present X or Y values when in Rectangular mode. A field is locked when the character icon is depressed.

#### D = toggle Distance lock, A = toggle Angle lock

<D> or <A> can be selected to lock the Distance or Angle in the Polar coordinate system.

#### Enter = Smart Lock

Smart Lock will index to the closest axis and lock the opposite field value. For example, if the X value is indexed, the Y value will be locked at 0. This allows you to draw in one direction but snap to objects in the other direction. In Polar mode, if Distance is active, the Angle will be locked.

#### Q = Quit

Press <Q> to quit AccuDraw.

# IBUG Fall User Group Meeting September 28<sup>th</sup> 2011



## V = View rotation

Press <V> to rotate the compass to align with the view axis. This is especially useful when working with rotated views.

## O = Set Origin

Pressing <O> moves the compass to the current pointer position or a tentative point. This is very helpful when combined with AccuSnap.

## RQ = Rotate Quick

<R><Q> temporarily changes the rotation of the compass to a user defined angle. Once a data point has been entered, the compass resumes its normal orientation.

## ~ = Bump Tool Setting

The tilde <~> character (no <Shift> key required) is used to bump the value of the first adjustable setting in the tool settings window to the next valid value. For example, when using the Place SmartLine tool, Bump Tool Setting will change the Segment Type from Line to Arcs.

## K = Keypoint Snap Divisor

Opens the Keypoint Snap Divisor dialog box, which is used to set the snap divisor for keypoint snapping.

## I = Intersect Snap

Activates Intersect snap mode.

## C = Center Snap

Activates Center snap mode.

- **NOTE:** Note that shortcuts can be customized. The list of shortcuts is controlled by a .txt file called **shortcut.txt**

One important concept is that AccuDraw has answers. These are not answers about how to do something, but the answers to a problem you are trying to solve. Many times you need to copy a measurement or do a calculation. AccuDraw does that for you.

An important feature is that you can place an AccuDraw origin at a tentative point. By snapping to a point and then pressing the <O>, the Origin shortcut, you can place the AccuDraw origin at that point. Do not accept the tentative point, just tentative snap and press <O>.

- **NOTE:** Remind yourself not to automatically accept the tentative snap. Just tentative snap and press <O>.



In the following exercise you will place a rotated block at the same angle as an existing line. Without AccuDraw, this might take several minutes and require many steps. AccuDraw simplifies the process.

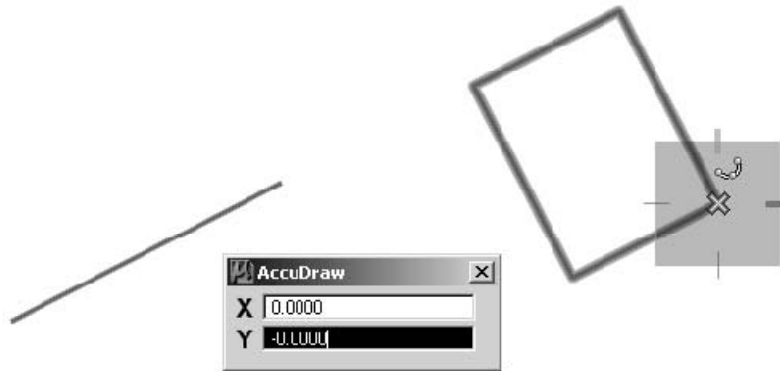

**Exercise: Using a series of AccuDraw commands**

1. Continuing in the Base Geometry.dgn, Pan to an open area of the design.
2. Set the following in the Attributes tool bar:

*Level:* Object  
*Color:* 0  
*Style:* 0  
*Weight:* 1

3. Select Place SmartLine (Q + 1).
4. Place a line at any angle. The length of the line is not important.

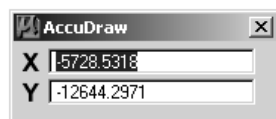

# IBUG Fall User Group Meeting September 28<sup>th</sup> 2011



5. Select Place Block (W + 1) with the following tool settings:

*Method:* Orthogonal

*Area:* Solid

*Fill Type:* None

6. Snap to the upper right end of the skewed line and press <O> for Origin. DO NOT enter a data point to accept the snap point.

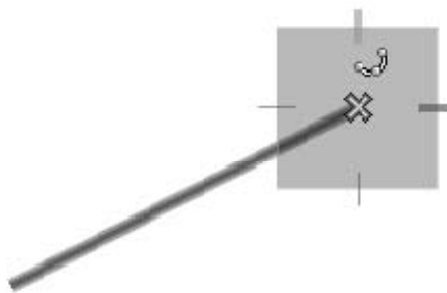

7. Press <RQ> to Rotate Quick.

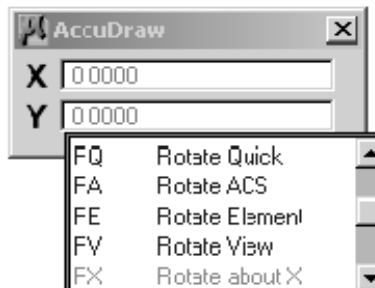

*RQ allows the compass to be spun around and re-oriented*

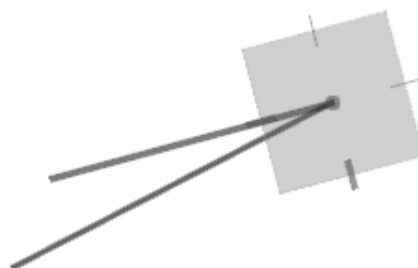
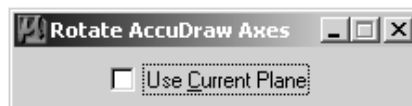

*Rotate AccuDraw Axes command and tool setting from RQ*



8. Note the prompt in the status bar.  
The Rotate Quick command requires you to define the X-axis.
9. Move the pointer towards the other end of the line and AccuSnap to the end. Enter a data point at this location.

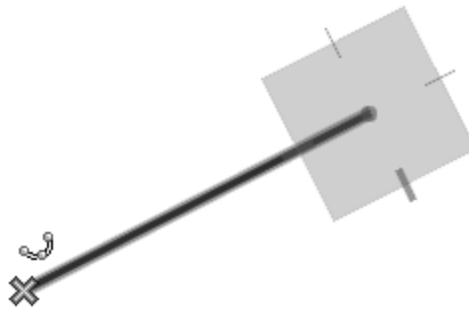
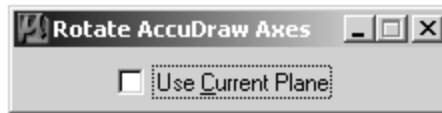

The compass has rotated to the angle of the line.

- **NOTE:** An even faster method would be to AccuSnap first then press <RQ>. Using this method you do not need to enter a data point.
10. Note that you have returned to the Place Block command.
  11. Move the pointer along the X-axis and towards the right and index to the negative Xaxis, while keeping the Y value zero. Enter a value of 1000 units.

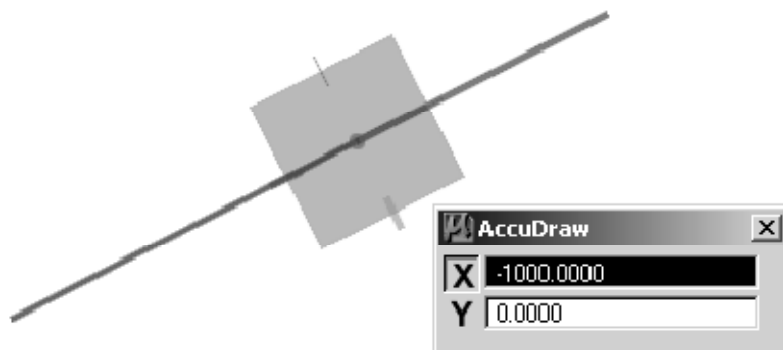

12. Accept with a data point

# IBUG Fall User Group Meeting September 28<sup>th</sup> 2011



Note that the direction, up and to the right, not the dimension, -X, is the important thing to think about in the previous step.

You have now placed the first corner point of the block. It is rotated even though the Method was set to Orthogonal.

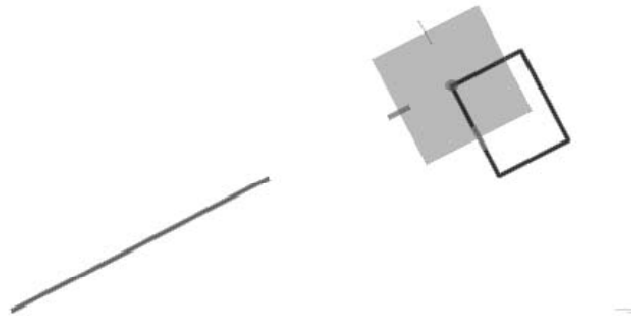

13. Move in the X direction and enter a value of 750.

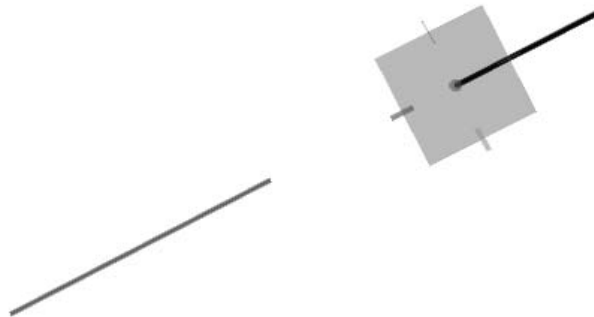

14. Move in the Y direction and enter a value of 1000.

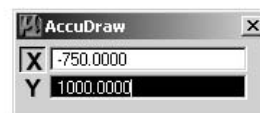
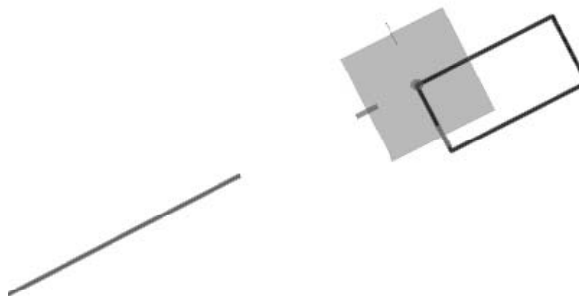



15. Enter a data point to accept the 750mm by 1000mm block.

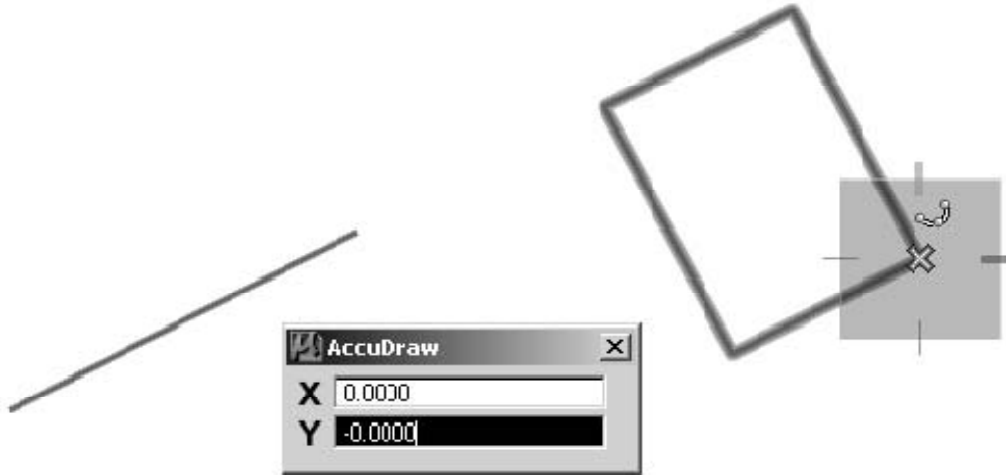

**In the next exercise** you will draw an oval shaped element around an inner rectangle. The only information you will have is the minimum clearance distance from the rectangle.

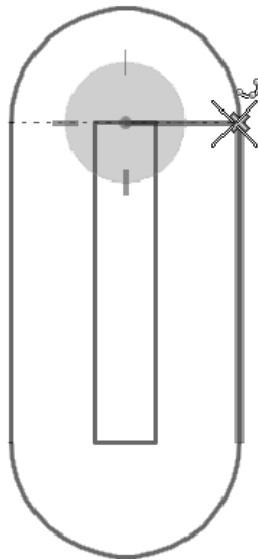

➤ **Exercise: Use more AccuDraw shortcuts**

1. Continuing in Base Geometry.dgn, Pan to an open area of the design.
2. Select Place Block (W + 1) with the following tool settings:

## IBUG Fall User Group Meeting September 28<sup>th</sup> 2011



*Method:* Orthogonal  
*Area:* Solid  
*Fill Type:* None

3. Following the status bar prompt, place a vertical block of any size.
4. Select Place SmartLine (Q + 1).
5. Read the status bar prompt and note that MicroStation requires a data point to define the first vertex. The first vertex will be offset from the top right corner of the block.
6. Move the pointer to the top right corner until you see the AccuSnap X.
7. Press <O> to move the AccuDraw compass to this location.

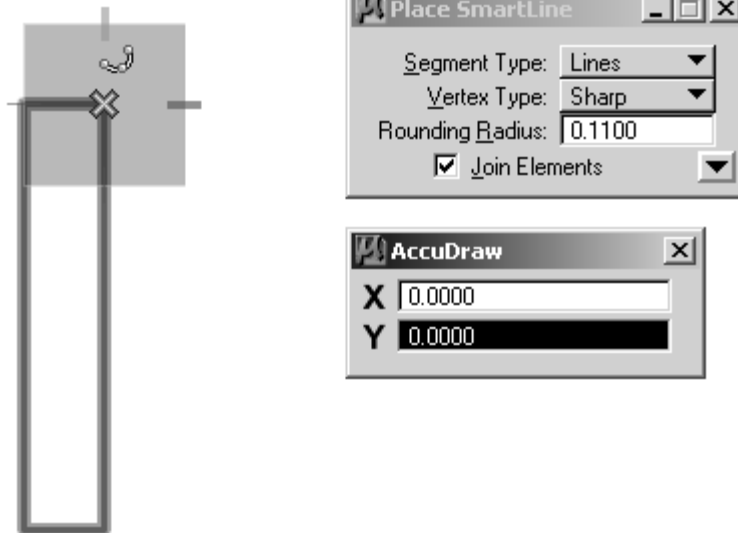



- 8. Index along the X-axis and enter a distance that is appropriate for the current zoom level.

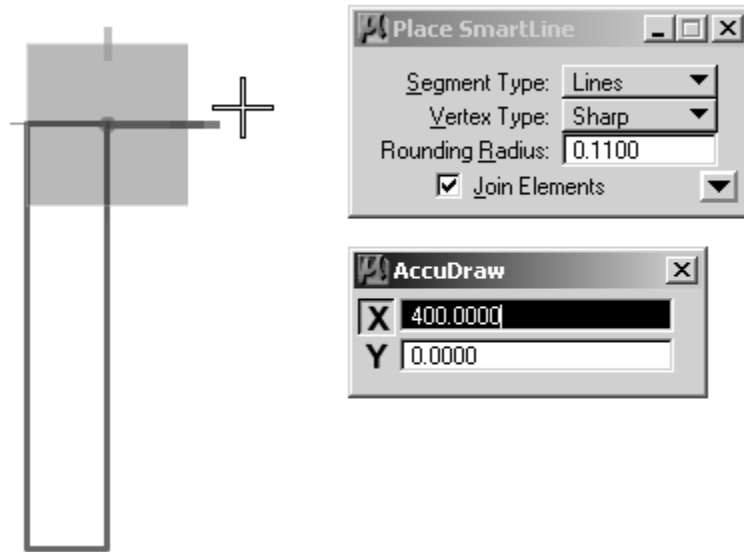

- 9. Note the status bar prompt and enter a data point for the first vertex of the SmartLine.

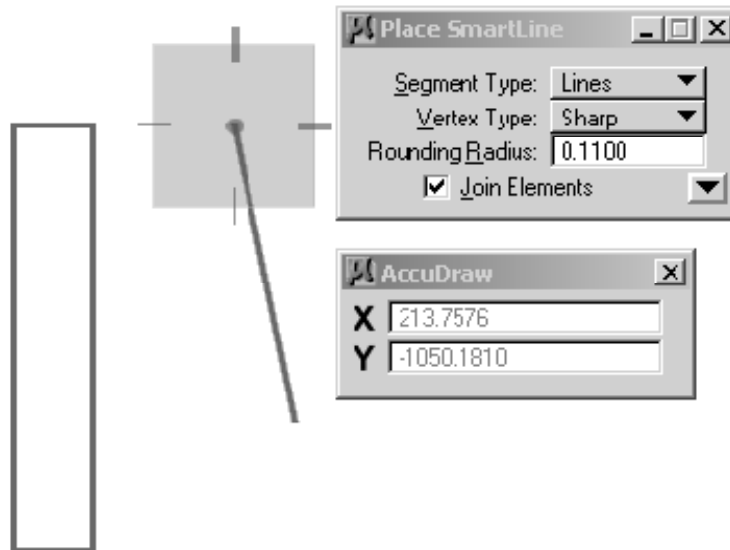



10. Move the pointer downward and press <Enter> to lock the axis.

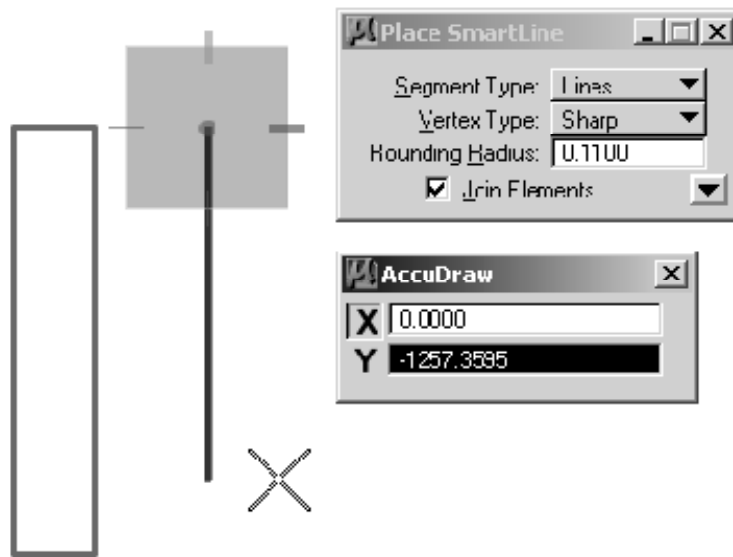

*SmartLock indexed to the nearest axis and locked X at 0*

11. Snap to the lower right corner of the block and enter a data point. This establishes the length of the line segment.

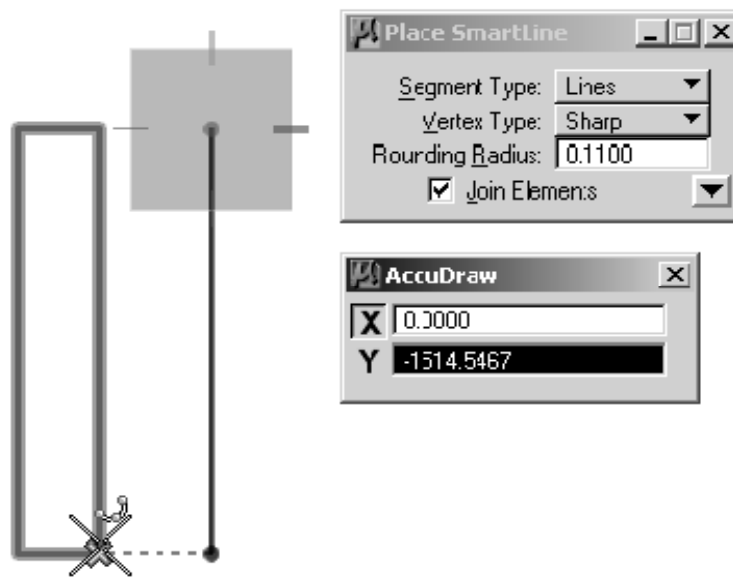

*Dashed line indicates that X is locked at 0*



- 12. With focus in the AccuDraw window, press the <~> key to change the Segment Type from Lines to Arcs.

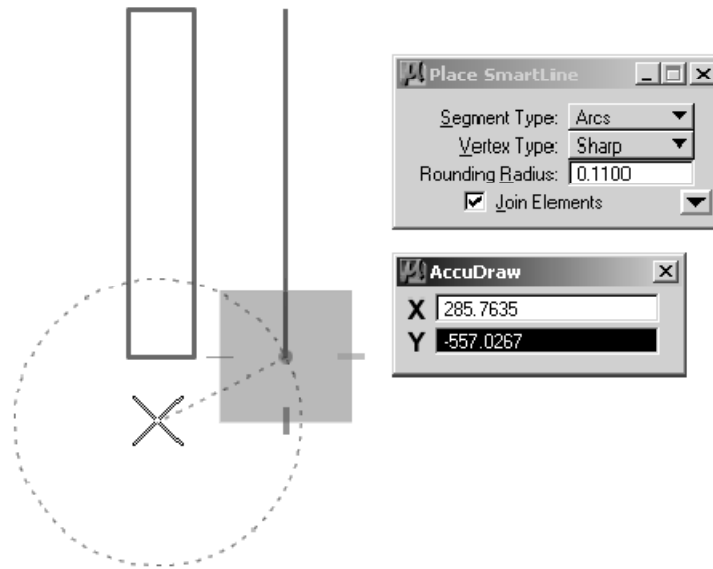

The status bar indicates that you need to define the location of the arc center.

- 13. Move the pointer to the midpoint of the block's lower edge and enter a data point when you see the AccuSnap X.

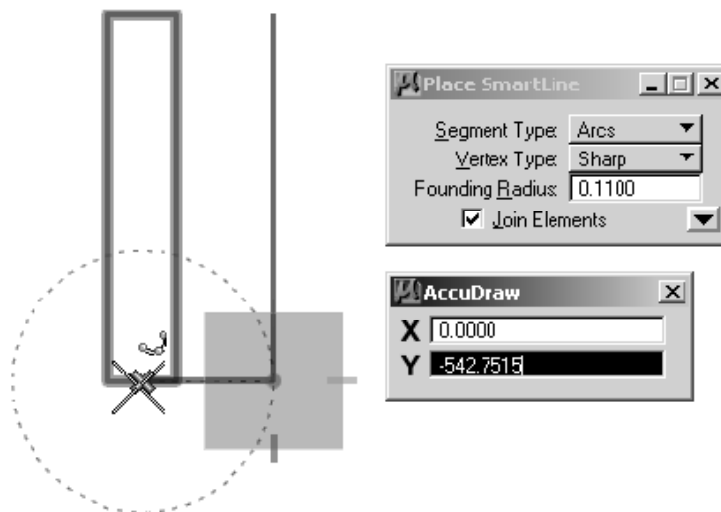

This becomes the center of the arc.



Next you need to define the sweep angle of the arc.

- 14. Move the pointer clockwise and sweep through 180 degrees. Enter a data point to accept the sweep.

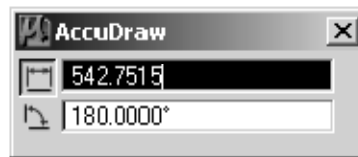
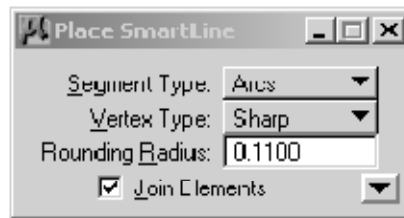
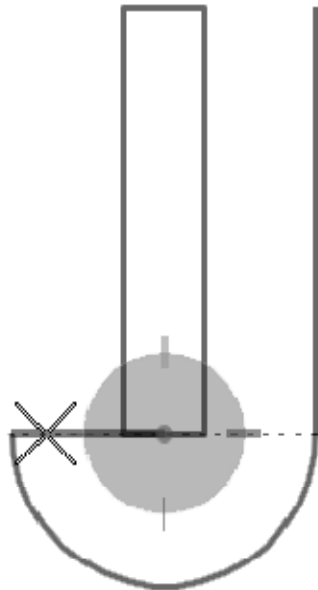

*AccuDraw indexing makes 90 degree increments easy to draw*

- 15. Press the <~> key to change the Segment Type to Lines.

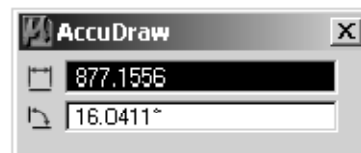
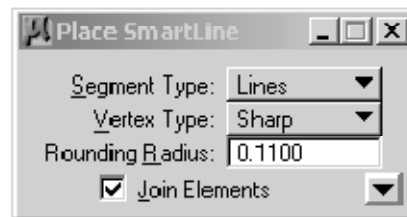
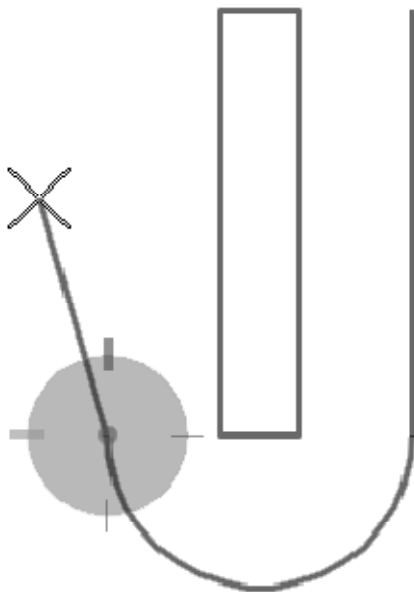



- 16. Move the pointer up to the top of the view and press <Enter> to SmartLock.
- 17. Snap to the upper left corner of the rectangle and enter a data point to fix the length of the line segment.

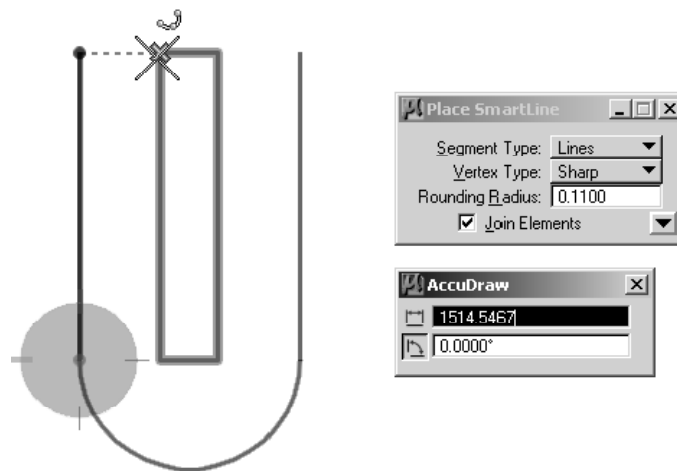

- 18. With focus on the AccuDraw window, press <~> to change the Segment Type to Arc.
- 19. Following the status bar prompt, snap to the mid-point of the top of the rectangle.
- 20. Enter a data point to accept this as the location for the center of the arc.

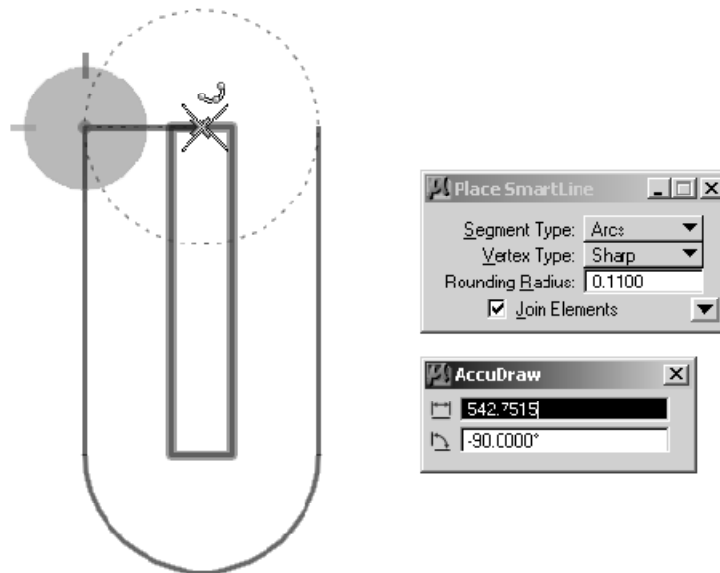



21. Move the pointer clockwise to draw the 180 degree arc and complete the oval.

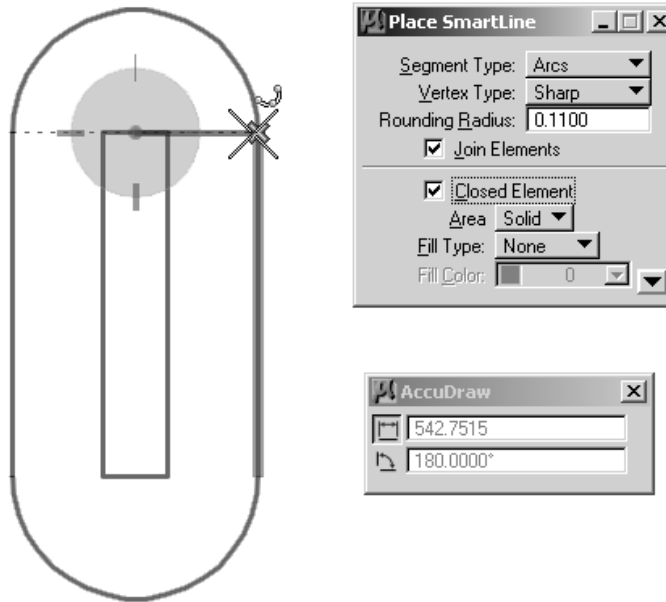

## AccuDraw Settings

Many aspects of AccuDraw's behavior can be set using custom settings. Set them in the AccuDraw's Settings dialog box. Use one of the following methods to access it.

- Select *Settings > AccuDraw*.
- Press <GS> while the input focus is on the AccuDraw window.
- Right click on the AccuDraw icon in the Primary Tools tool box and select Properties.

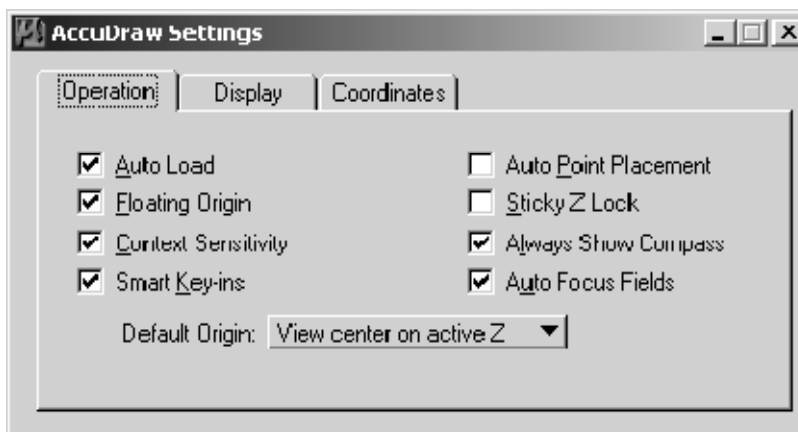



## Operation tab

### Auto load

The Auto Load setting forces AccuDraw to open at the beginning of each session. Turn this off if you would rather use the Toggle AccuDraw tool to start AccuDraw manually.

### Floating origin

The floating origin is turned on by default. It instructs AccuDraw to move the compass to the last data point. The AccuDraw compass remains in a fixed position until you enter another data point or re-issue the origin with the <O> shortcut. Floating origin must be on for all context sensitivity features to perform properly.

### Context sensitivity

When this setting is on, context sensitivity enables tools to provide hints to AccuDraw to override its default behavior for smoother operation. This can include setting custom context rotations, setting the origin, locking values, or setting the coordinate system type.

### Auto focus fields

If on, the <A> and <D> AccuDraw shortcuts set focus to the selected field and lock the current value.

If off, the <A> and <D> AccuDraw shortcuts lock the current value without affecting the focus. This setting is for Polar coordinates only.

## Display tab

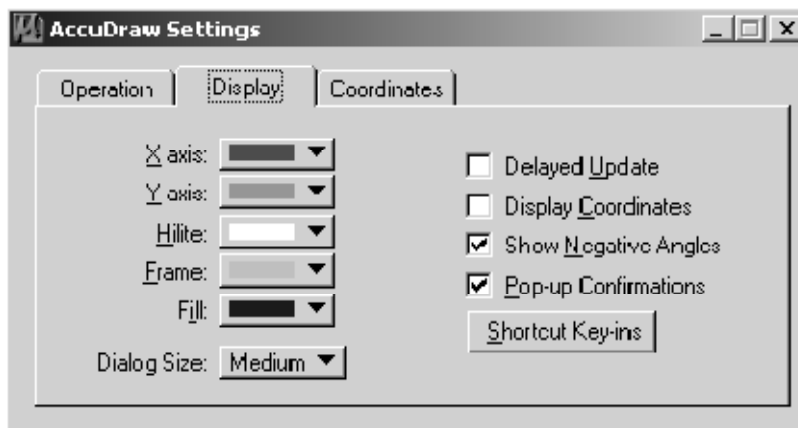

This tab contains settings that change the various display features. This includes items such as the colors of the axis ticks, the highlight when indexing, the frame and the fill.

# IBUG Fall User Group Meeting September 28<sup>th</sup> 2011



In addition, there are three key-in commands that are entered from the keyboard that can affect AccuDraw's display.

- AccuDraw Settings Size xx  
Where xx is a value between 6 and 399. This sets the size of the AccuDraw compass which has a default size of 40.
- AccuDraw Settings NE  
Will change the display of AccuDraw's key-in window from X and Y to N (Northing) and E (Easting).
- AccuDraw Settings XY  
Will change the display of AccuDraw's key-in window to X and Y.

## Coordinates tab

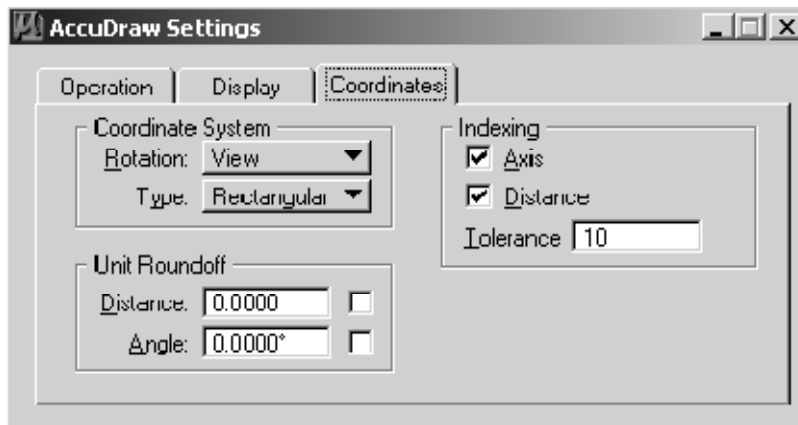

This tab is used to define the Coordinate System, Unit Roundoff, and Indexing settings.

### Coordinate System

Contains controls that are used to rotate AccuDraw's drawing plane and to set AccuDraw's Coordinate System.

#### Rotation

Sets the rotation of the drawing plane axes. While the AccuDraw window has the focus, pressing the key combination indicated in parentheses has the same effect as choosing the specified rotation.

#### Type

Sets the method used in the AccuDraw window to specify distances and angles relative to the drawing plane origin.



## Unit Round Off

Contains controls that are used to set the incremental round off value for distances and angles relative to the drawing plane origin in the Polar Coordinate system only.

### Distance

Sets the roundoff value for distances relative to the drawing plane origin. When this is on, the roundoff value is effective, except if overridden by keyed in values or snapped tentative points.

### Angle

Sets the roundoff value, in degrees, for angles relative to the drawing plane origin when in Polar mode. While the check box is on, the roundoff value is effective except if overridden by keyed in values or snapped tentative points.

➤ **NOTE:** These settings do not affect keyed in values and snapped tentative points.

## Indexing

Controls the settings for AccuDraw's indexing to axes, the origin and the previous distance entered.

### Axis

If on, indexing is activated for AccuDraw's drawing plane X and Y axes. The distance required to move the pointer from the indexed axis is controlled by the Tolerance setting.

### Distance

If on, sets the minimum distance that the pointer must move from the AccuDraw origin in order to place a new data point. The minimum distance is controlled by the Tolerance setting.

### Location Tolerance

Sets the minimum distance, in screen pixels, used by the Axis and Distance settings. Allowable values are 1 to 99.

## Pop-up Calculator

The pop-up calculator allows you to perform mathematical operations on the fly. It is activated by pressing +, -, \*, /, = in any text field that supports it. This includes AccuDraw's key-in fields and many other fields, such as Active Angle or Active Scale.

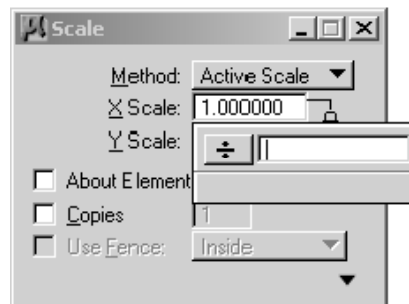

## IBUG Fall User Group Meeting September 28<sup>th</sup> 2011



The pop-up calculator can also perform advanced mathematical functions including the use of trigonometric and logarithmic functions, multiple operators, parentheses, and C expressions.

### Invoking and using the pop-up calculator

You can invoke the pop-up calculator in two different modes. The first method applies the mathematical expression to the existing value displayed in the field with focus. To activate this mode, press either  $\langle + \rangle$ ,  $\langle - \rangle$ ,  $\langle * \rangle$ , or  $\langle / \rangle$ .

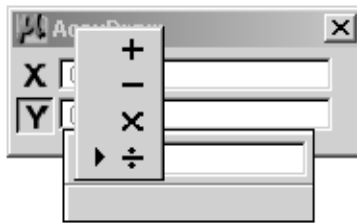

The second mode is activated by the  $\langle = \rangle$  key and replaces the existing value with the results of a keyed in expression or calculation. In this mode, the result dynamically updates in the original field, rather than having a field of its own in the pop-up. This feature is usually used for more complex expressions.

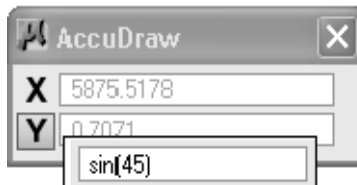



➤ **Exercise: Using the pop-up calculator**

1. Continuing in Base Geometry.dgn, Pan to an open area of the design.

2. Select Place SmartLine (Q + 1) with the following tool setting:

*Segment Type: Lines*

3. Following the status bar prompt, place the first vertex anywhere in the view.

4. Index to the X-axis and press <Enter> to SmartLock.

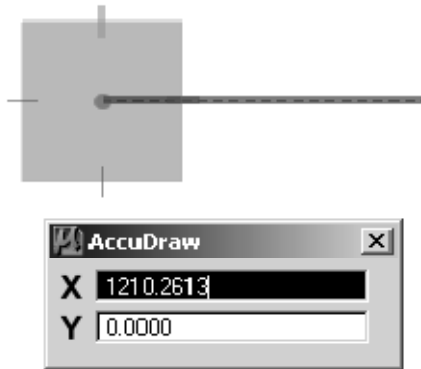

5. Enter 1500.

6. Press the </> key to open the pop-up calculator in the division function.

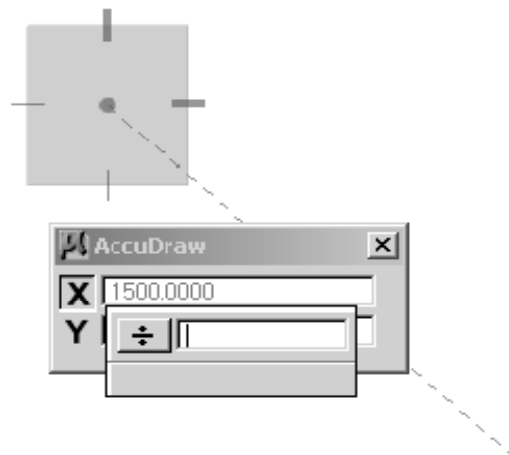

# IBUG Fall User Group Meeting September 28<sup>th</sup> 2011



7. Enter 7 into the calculator field.

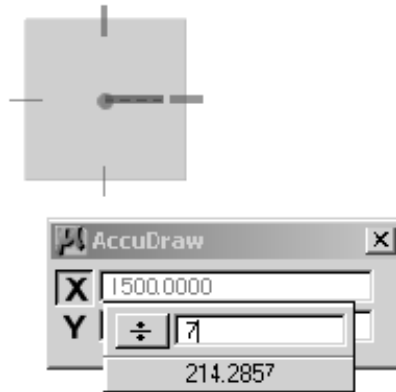

*The result is shown numerically and graphically*

8. Enter a data point to accept the second vertex.

9. Index to the Y-axis.



10. Enter 750.

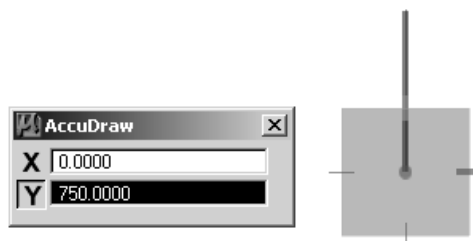



11. Press the <\*> key to open the pop-up calculator in the multiplication function.

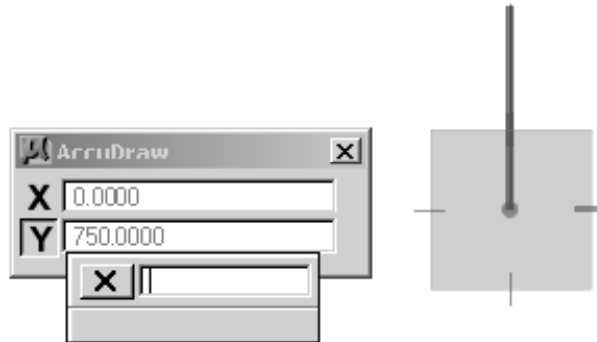

12. Enter 1.375 into the calculator field and accept the resulting value with a data point.

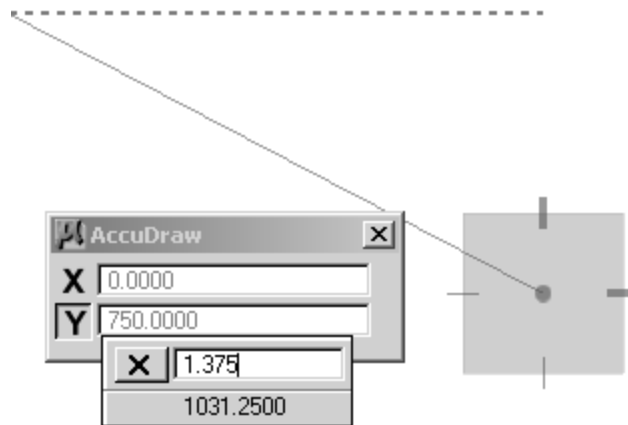

13. There are other uses for the pop-up calculator, such as finding a distance halfway between two objects.

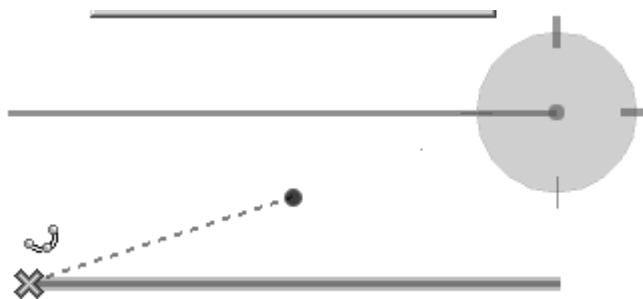

## IBUG Fall User Group Meeting September 28<sup>th</sup> 2011



### ➤ Exercise: Use the pop-up calculator to find a distance

1. Continuing in Base Geometry.dgn, Pan to an open area of the design.
2. Select Place SmartLine (Q + 1).
3. Enter the first vertex anywhere.
4. Index to the X-axis and enter a second data point anywhere along the X-axis
5. Draw another line below the first one.



6. Select Place Circle (E + 1) with the following tool settings:

*Method:* Center

*Area:* Solid

*Fill Type:* None

You are prompted to enter the center point of the circle.

7. AccuSnap to the right end of the upper line.
8. With focus in the AccuDraw window, press <O> to set the origin at the snap point.
9. Snap to the left end of the lower line



10. Press the space bar to switch to Polar mode.

The Distance field displays the linear distance from the origin to the current location of the pointer.



11. Press  $\langle \rangle$  and enter 2 in the calculator field.

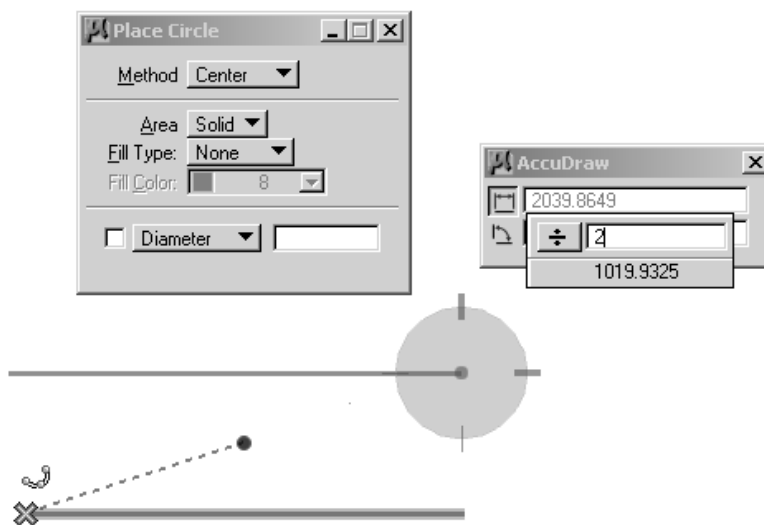

This divides the distance by two.



12. Accept the circle center point with a data point.
13. Following the status bar prompt, enter a radius of 100 and accept with a data point.
14. Select *File > Close*.

The pop-up calculator can also do trigonometric, logarithmic, exponential and other mathematical functions. For a complete list of available mathematical functions please refer to the on-line Help; *Working with Completed Designs > Visualization > Animation > Parametric Motion Control > Scripting Parametric Motion > to script parametric motion*.

### AccuDraw and Element Placement in 3D

Placing elements in a 2D file is as simple as drawing on a sheet of paper. All elements are on one plane, the x,y plane. When you place the same elements in a 3D file, by default they are placed in the AccuDraw drawing plane. The AccuDraw drawing plane can be rotated to match the view you are using, or it can be defined to be a particular rotation. In the following exercises you will draw an open rectangular box using 2D blocks.

#### ➤ Exercise: Open the model and draw the base surface

1. Set the following in the MicroStation Manager:  
*User: Untitled*  
*Project: untitled*
2. Open AccuDraw\_3D.dgn.
3. Open model AccuDraw\_01.  
You can see the ACS triad in each view. It indicates the directions of the 3 axes. You toggle the display of the ACS triad in the View Attributes dialog box.
4. Click the Task List icon and make the Basic 3D task the active task.
5. With focus in the AccuDraw window, press <V> on the keyboard.

This is the AccuDraw shortcut for View orientation.

First you will draw the base of the box using the Top view. You will use AccuDraw to input precise dimensions for the block. This part of the exercise is no different than working in 2D.



6. Select Place Block (Q + 2 +1).
7. Enter a data point in the lower left corner of the Top view.
8. Move the pointer to the right and, with it indexed to AccuDraw's x-axis, key-in 1.5 and do NOT enter a data point.
9. Move the pointer upward and enter 1.25.
10. Enter a data point to complete the block.
11. Fit each view.

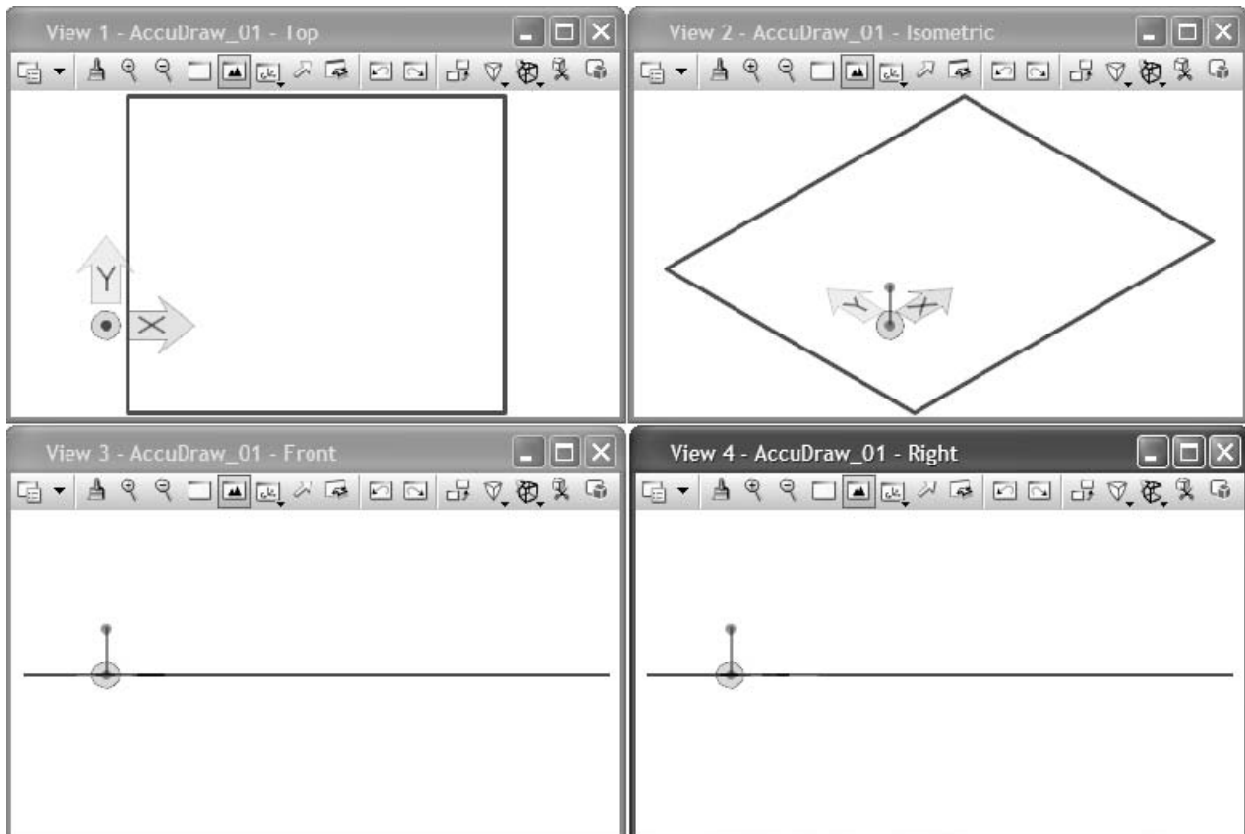

- **Note:** The block appears as a line in both the Front and Right views, where it is edge-on to the view. It is like looking at a sheet of paper edge-on.

## IBUG Fall User Group Meeting September 28<sup>th</sup> 2011



Next, you will use the Front and Right views to draw the corresponding front and right faces of the box. Each view has an active depth, where data points fall by default if you do not snap to an element. Here, you will snap to the block that you just drew and use AccuDraw to keep the pointer at that depth in the view.

### ➤ **Exercise: Use Front and Right views to draw corresponding faces for the box**

1. Continuing in model AccuDraw\_01, select Place Block (Q + 2 +1).
2. In the Front view, snap to the left end of the existing block, which appears as a line in this view, and accept with a data point.
3. Move the pointer to the right and, with it indexed to AccuDraw's x-axis, key-in 1.5.
4. Move the pointer upward, enter 0.5, and enter a data point to complete the block.
5. Fit each view.  
For the right face, you can snap to existing elements to place the points.
6. Select Place Block (Q + 2 +1).
7. In the Right view, snap to the right end of the base (the horizontal line) and accept with a data point.
8. Continuing in the Right view, snap to the top of the front surface (the vertical line) and accept with a data point.  
As you do this, watch the Isometric view to ensure that you are snapping to the correct points and that you are placing the block correctly.
9. Fit each view.

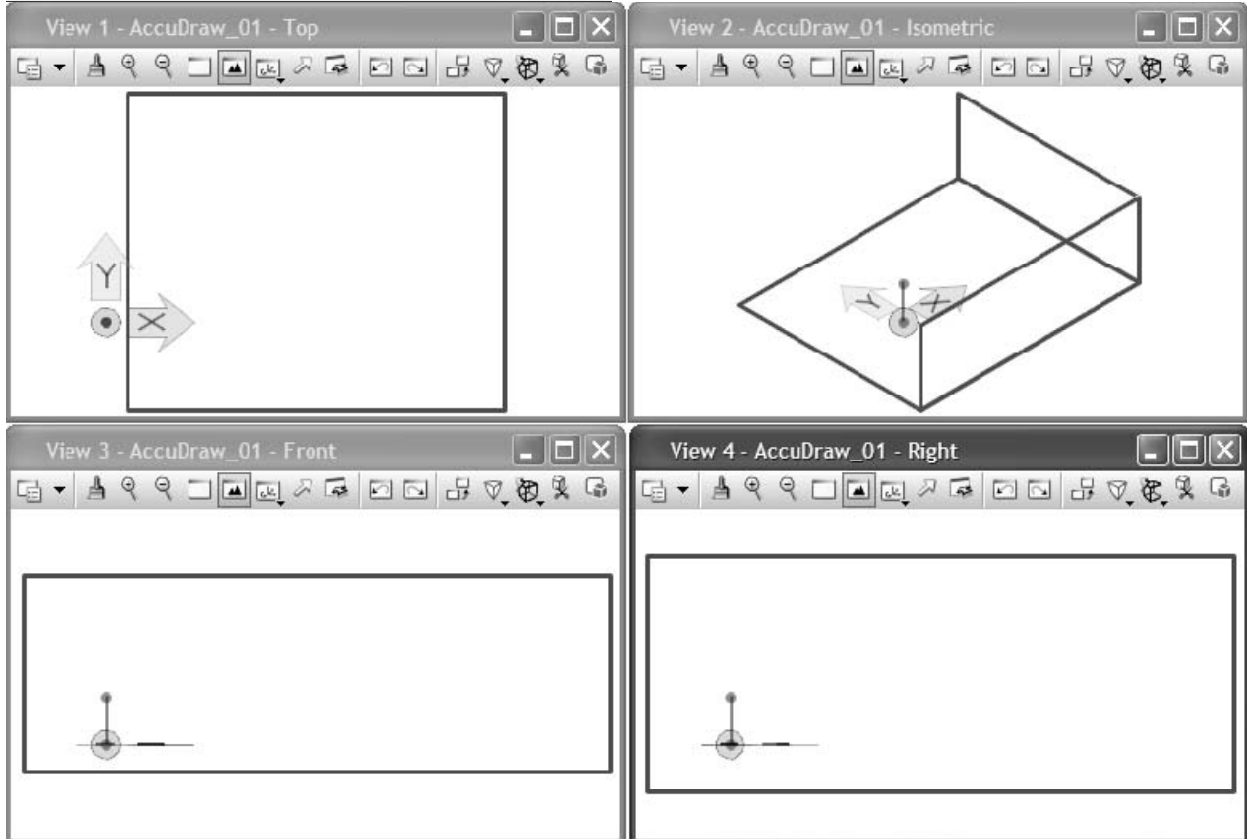

To complete the box, you can use the copy tool to copy the existing faces and create the opposite sides. When you copy an element in 3D, it retains its current orientation. That means a vertical face remains vertical, a horizontal face remains horizontal, and so on.

➤ **Copy the existing faces to complete the box**

1. Continuing in model AccuDraw\_01, select Copy Element (3 + 1) with the following tool setting:

*Copies: 1*

2. In the Front view, identify the block representing the front face at its lower left vertex.

The face is attached to the pointer. As you move the pointer in the other views, the front face element retains its current orientation.

3. In the Isometric view, snap to the back left vertex of the base block and accept to complete the copy.

## IBUG Fall User Group Meeting September 28<sup>th</sup> 2011



4. Reset.
5. In the Right view, identify the block representing the right face at its lower right vertex.
6. In the Isometric view, snap to the back left vertex of the base block and accept to complete the copy.

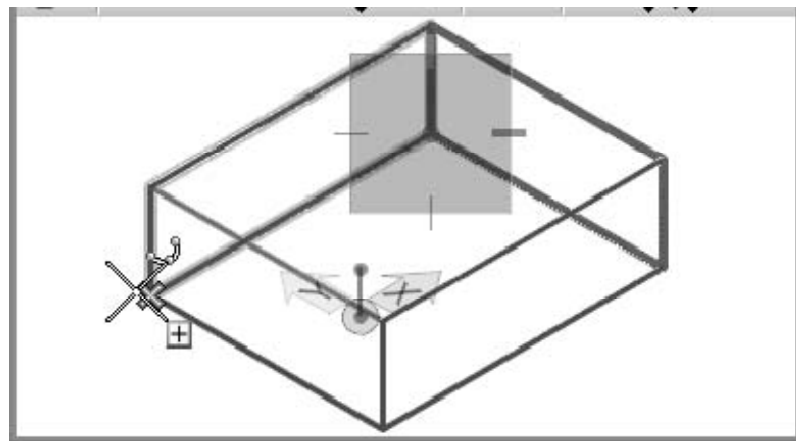

7. Reset.
8. Click the View Display Mode view control in the Isometric view's view control tool box and change the display mode to Hidden Line.
9. Select Rotate View.
10. Rotate the Isometric view and make sure that you have correctly drawn all the surfaces for the open box.

Placing elements in 3D is no more difficult than in 2D. In this exercise, you used MicroStation's views to help you correctly orient the elements. Of the four views, the Isometric view displays the model best. You can see the three faces clearly.

Other tools that rely on the view orientation also can be used with AccuDraw. For example, the tools for Mirror, Rotate Element and Array all use the view orientation to define the direction of the mirror or the axis of rotation.

### ➤ Exercise: Using AccuDraw to mirror copy

1. Open model AccuDraw\_04 in AccuDraw\_3D.dgn.

This model has been saved with a large Isometric view in which to work and smaller Top, Front, and Right views to use to check your work.



2. Select Mirror (3 + 5), with the following settings:

*Mirror About:* Vertical  
*Make Copy:* On  
All other settings Off.

3. Identify the end chair at location 1.

The AccuDraw compass indicates that it is in View mode. When you move the pointer, the chair is mirrored about a vertical line in the Isometric view.

4. Press <T> to set AccuDraw to Top view rotation.

The chair is mirrored about a vertical line in Top orientation. You can see this clearly in the orthogonal views.

5. Snap to the table base at location 2 and accept with a data point.

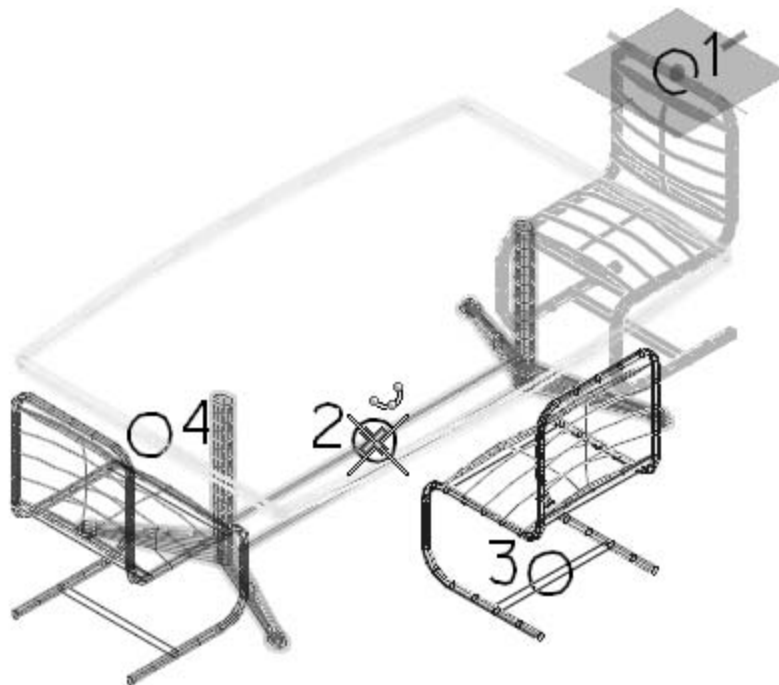

6. Reset to complete the operation.

## IBUG Fall User Group Meeting September 28<sup>th</sup> 2011



7. Change the Mirror About setting to Vertical.
8. Identify the side chair at location 3.
9. Snap to the center of the table edge at location 4 and accept with a data point.
10. Reset to complete.

### Tentative Snaps and AccuDraw

In 2D, all elements are on the same plane. In 3D, the elements often are on different planes. Sometimes when working in 3D you will locate elements relative to others already present in the model.

In the following exercise you will place a SmartLine to represent a paved area for a building complex.

#### ➤ Exercise: Draw the paved area for the building complex

1. Open model AccuDraw\_06 in AccuDraw\_3D.dgn.
2. Select Place SmartLine (Q + 1) with following tool settings:  
*Segment Type:* Lines  
*Vertex Type:* Rounded  
*Rounding Radius:* 1.5  
*Join Elements:* Enabled
3. Press <T> to switch to the Top plane.
4. Move the pointer down to the left and, with it indexed to the x-axis, press <Return> to constrain the point to this axis. Do not enter a data point.
5. Snap to the vertex at location 2 and accept with a data point.  
As you snap to the vertex, a dashed line displays back to the point you are placing, perpendicular to the x-axis. This is what you would expect in 2D.

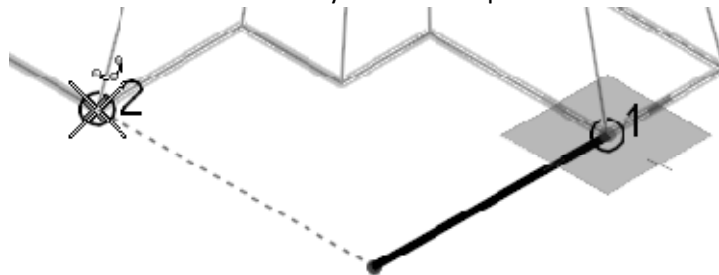



6. With the pointer still at location 2, press <Return> to constrain the next point to the y-axis.
7. Snap to the vertex at location 3.  
As you snap to the vertex, a dashed line displays from the snap point, vertically, down to the plane of the element that you are drawing and then across to the point that you are placing.
8. Accept with a data point.

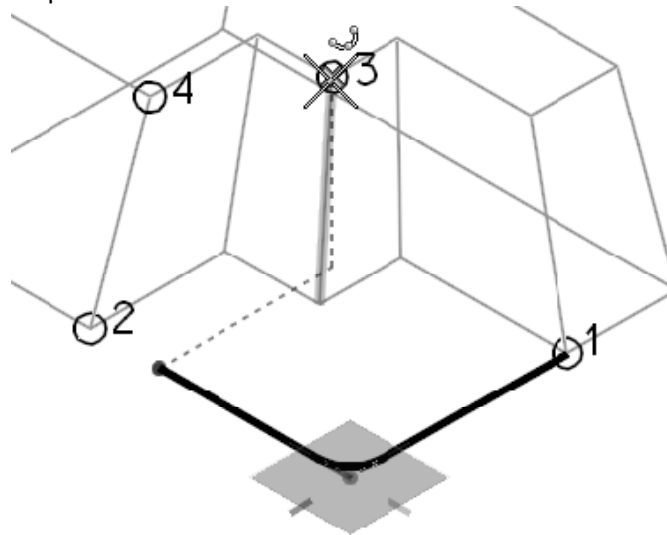

9. Position the pointer and press <Return> to constrain the next point to the y-axis.
10. Snap to the vertex at location 4 and accept with a data point.
11. Constrain the next point to the y-axis.
12. Snap to the vertex at location 2 and accept with a data point.
13. Reset to complete.

